



Specifications

PVE 1600 STAGE V / TIER 4F

Hydraulic Power Pack

USA

Dimensions in inches

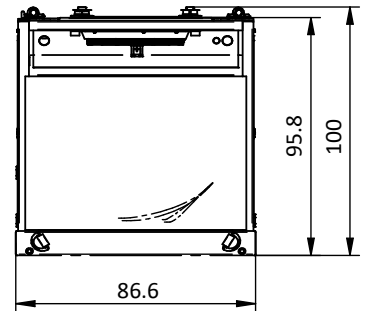
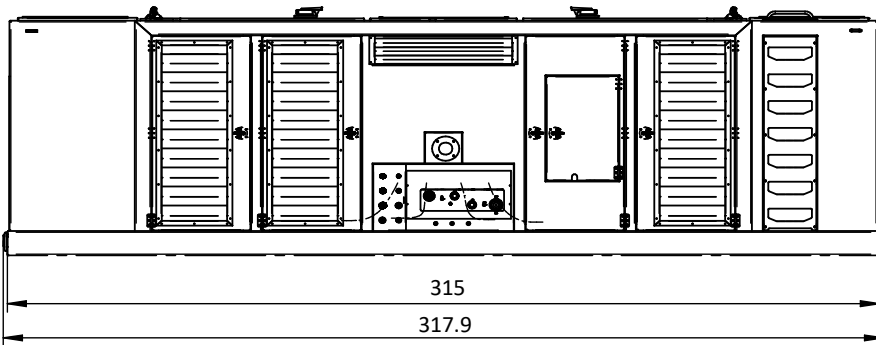
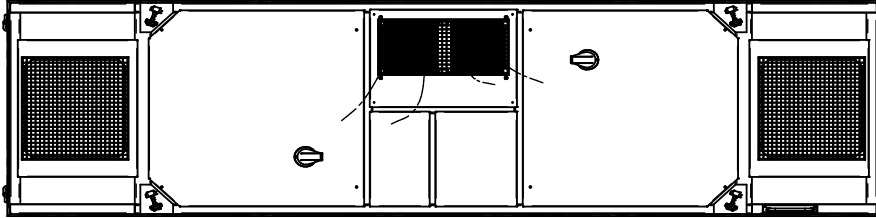

Specifications

PVE 1600 STAGE V / TIER 4F

Diesel Engine	Caterpillar C18 (2x)	
Max. theoretical power	1,126/1,510	kW/HP
Max. frequency	1,800	rpm
Max. operating pressure	5,076	psi
Hydraulic pump	Parker	
Max. oil flow	428	gal/min
Diesel Fuel	581	gal
DEF (AdBlue) capacity	N.A.	gal
Hydraulic oil	819	gal
Weight without fuel	35,450	lbs
Weight with fuel	39,683	lbs