

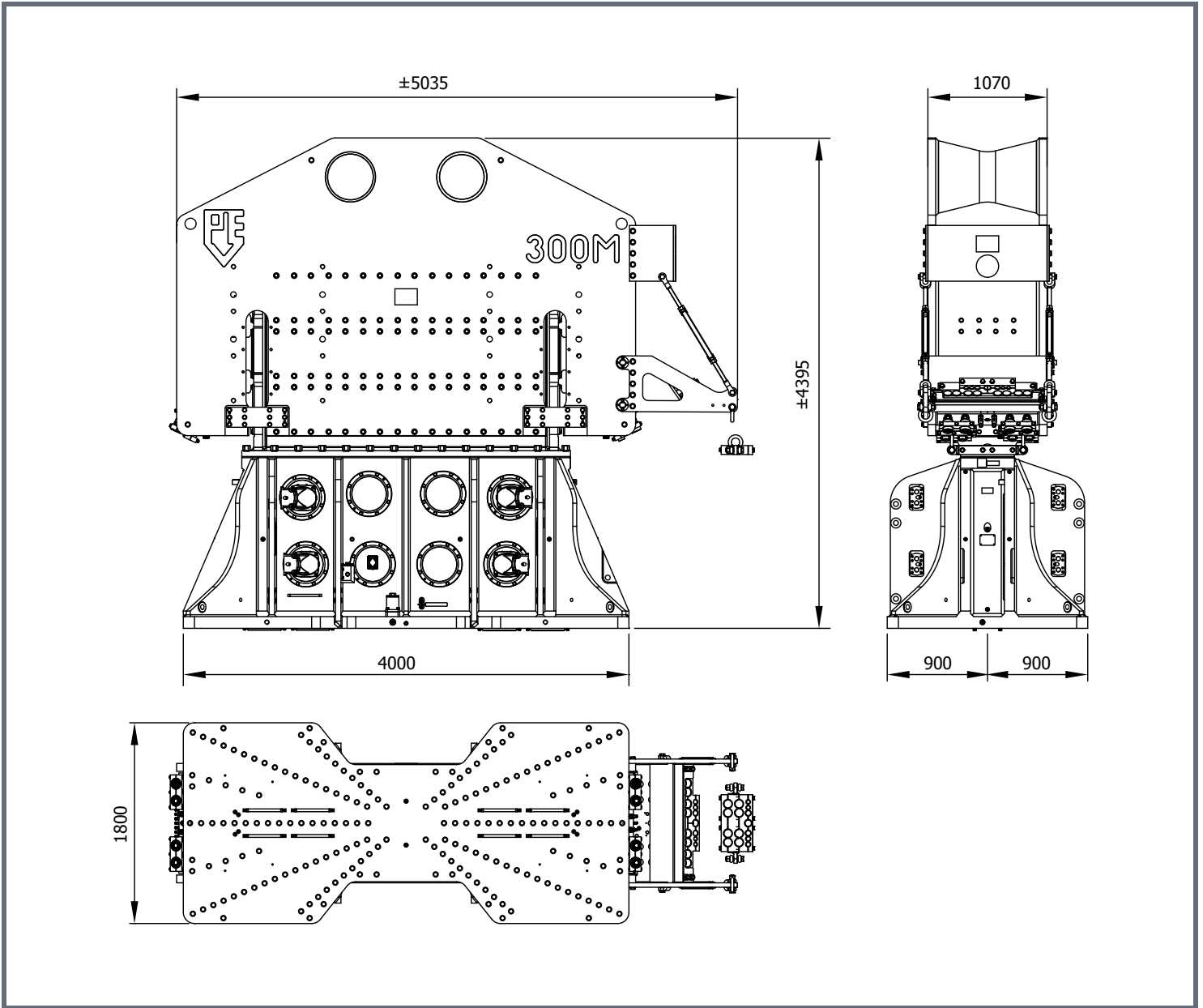

Specification Sheet

PVE 300M

Standard Frequency Vibro Hammer



Specifications

300M

Eccentric moment	24820	inch-lbs	Clamps:	
Max. centrifugal force	691	tons	Double clamps	PPK 210TC 4x
Max. frequency	1400	rpm	Transport weight per piece	3527 lbs
Max. amplitude excluding PPK 210TC	0.83	inch		
Max. amplitude including PPK 210TC	0.67	inch		
Max. static line-pull	450	tons		
Max. operating pressure	5080	psi	Powerpack:	
Max. oil flow	740	gpm	Model	3200
Forced lubrication	yes			
Dynamic weight excluding PPK 210TC	60080	lbs	Hose set:	
Dynamic weight including PPK 210TC	74190	lbs	Length	148 feet
Total weight excluding PPK 210TC & hoses	103620	lbs	Transport weight (±)	11464 lbs